

Dynisco SPX-T (3-Series)

GENERAL PURPOSE SMART PRESSURE SENSORS
FOR HAZARDOUS LOCATIONS

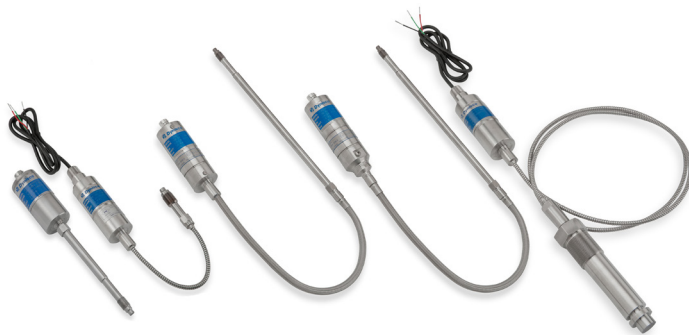

Description

The SPX-T (3-Series) is a smart 4-20mA pressure transmitter that includes Temperature Compensation and DynaLarity™, a Dynisco innovation. The SPX-T delivers the best spec performance in the line. Temperature Compensation is based on an RTD measurement that compensates for temperature variations which reduces temperature-related drift and increases accuracy. No need to re-zero for temperature changes after installation. DynaLarity uses an advanced algorithm that will linearize offsets due to process effects on the sensor. Combined Temperature Compensation and DynaLarity reduces temperature-related drift by as much as 80% and improves accuracy by more than 60% over other sensors. Process temperature output is available (RTD or 4-20mA). HART communication is standard. The SPX 3-Series is an all-welded construction designed for use in hazardous locations and are available with a variety of different process and electrical connections.

These amplified transmitters eliminate the need for external signal conditioning. All models can interface directly with distributed control systems, PLC's, computers, and similar high level control devices

Features

- 4-20mA loop-powered output
- +/- 0.15% accuracy available
- Reduced temperature drift by 80% over non compensated units
- Temperature output available (RTD or 4-20mA)
- Wide selection of pressure ranges available
- Turndown 6:1
- Configurations available for use in hazardous locations
- Remotely configurable via HART
- Precise, repeatable pressure measurements
- Output supplied directly to DSC or PLC
- Meets CE requirements
- CE ATEX Intrinsically Safe Approved
- FM Explosion proof approved
- CSA Explosion proof approved
- SIL 2 Certified (pressure output)
- PL'c' Certified (relay output)
- Additional approvals are available

Performance Characteristics SPX-T (3- Series)	
Output	4 - 20 mA, with optional HART™
Input Voltage	16 - 36 Vdc (Std); 16 - 30 Vdc (ATEX IS)
Accuracy	<p>32XX: ± 0.25% for pressure ranges ≥ 3,000 psi ± 0.5% for pressure ranges = 1,500 psi ± 0.75% for pressure ranges < 1,500 psi</p> <p>33XX: ± 0.15% for pressure ranges ≥ 3,000 psi ± 0.25% for pressure ranges = 1,500 psi ± 0.5% for pressure ranges < 1,500 psi</p> <p><small>Accuracy is defined as the combined error expressed as a percentage of full scale output with the specifications of: Electronics ambient temperature; Snout compensated temperature range; capillary of ≤ 36"; DyMax coated 15-5 SST diaphragm; Best Straight Line (BSL) %FS, per ISA-37.1. Consult Factory for availability and specifications of other configurations.</small></p>
Repeatability	±0.1%
Rangeability	6:1 Turndown
Over Pressure	1.5 x FSO
Load Resistance	500 Ω @ 24 Vdc, 1,000 Ω @ 36 Vdc
Electronics Ambient Temperature	70°F (20°C)
Electronics Operating Temperature	-20 to 185°F (-29 to 85°C)
Electronics Compensated Temperature Range	70 to 185°F (20 to 85°C)
Snout Compensated Temperature Range	70 to 572°F (20 to 300°C)
Snout Operating Temperature	Models: 3242, 3243, 3342, 3343: 32 to 752°F (0 to 400°C) Models: 3290, 3291, 3390, 3391: 32 to 600°F (0 to 315°C)

Mechanical Characteristics	
Mounting Torque	3242: 500 inch-lbf max 3243: 50 inch-lbf max 3342: 500 inch-lbf max 3343: 50 inch-lbf max 3290: 350 inch-lbf max 3291: 350 inch-lbf max 3390: 350 inch-lbf max 3391: 350 inch-lbf max
Standard Wetted Parts	DyMax coated 15-5 PH SST
Approvals & Certifications	
CE ATEX IS	
SIL 2 (pressure output) & PL'c' (relay output)	
FM & CSA Explosion Proof	
Additional Approvals are Available	

Ordering Guide for Models SPX3242¹

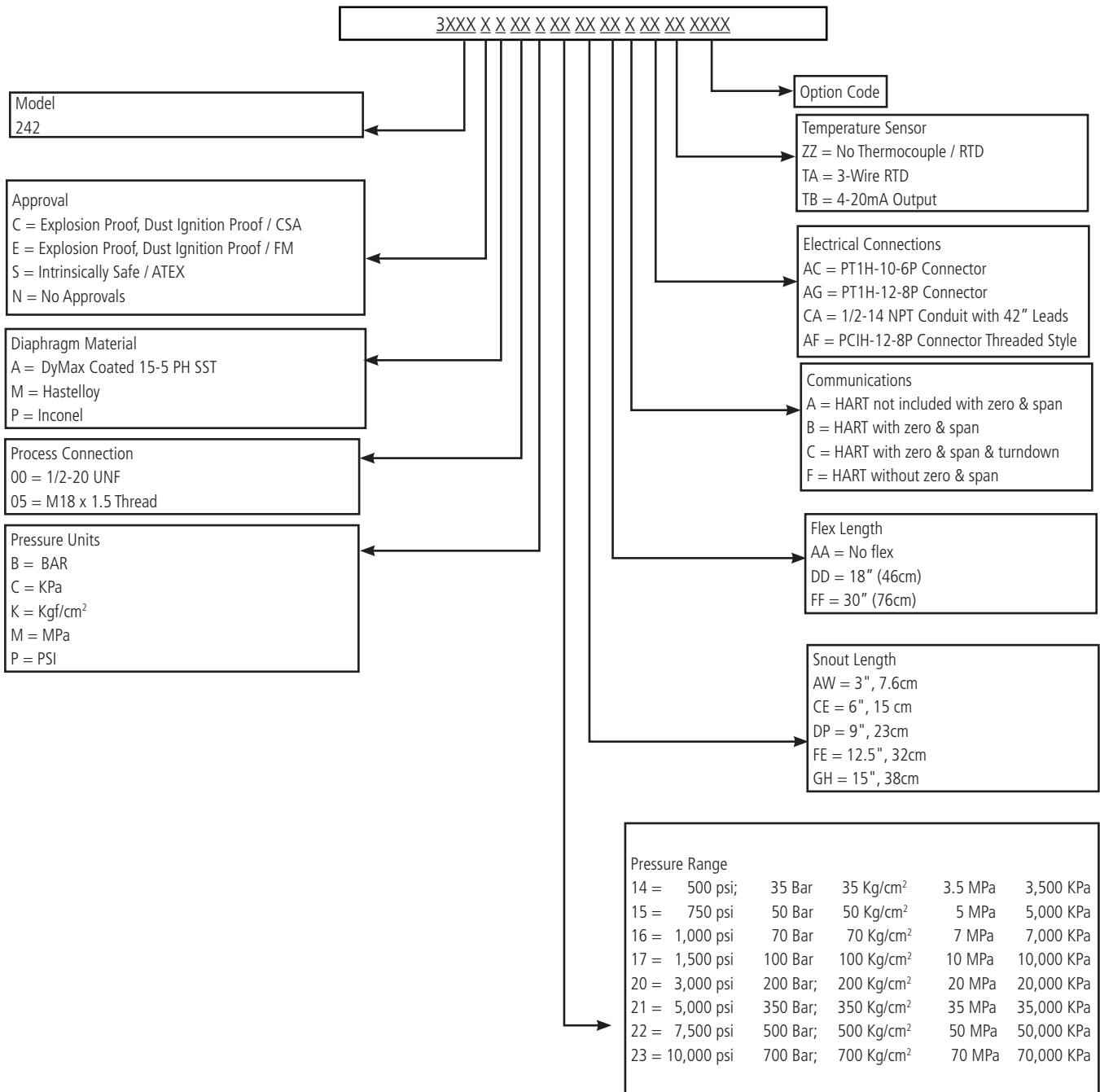

¹ Other configurations are available. Please consult factory.

Ordering Guide for Models SPX3243¹

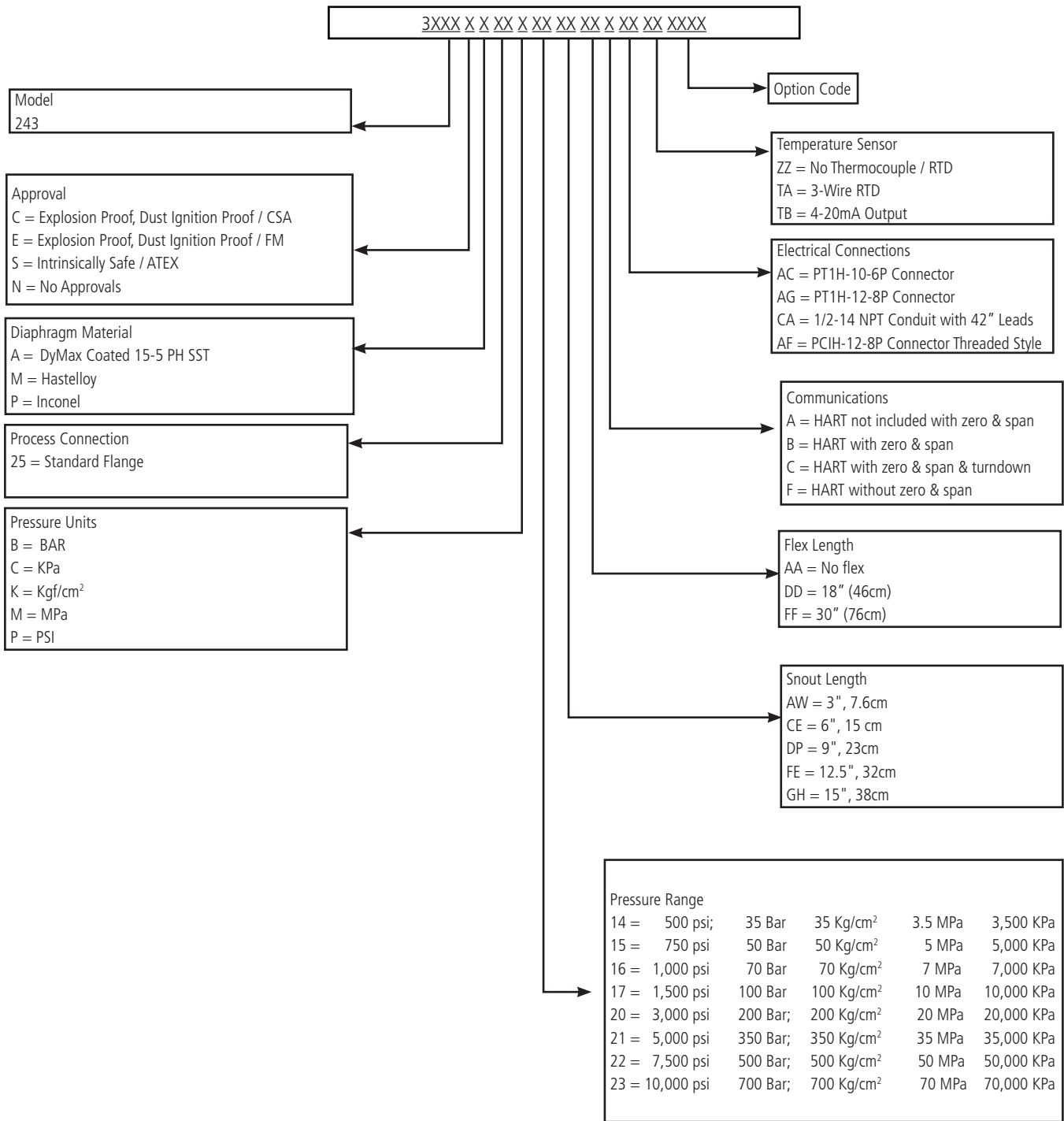

¹ Other configurations are available. Please consult factory.

Ordering Guide for Models SPX3342¹

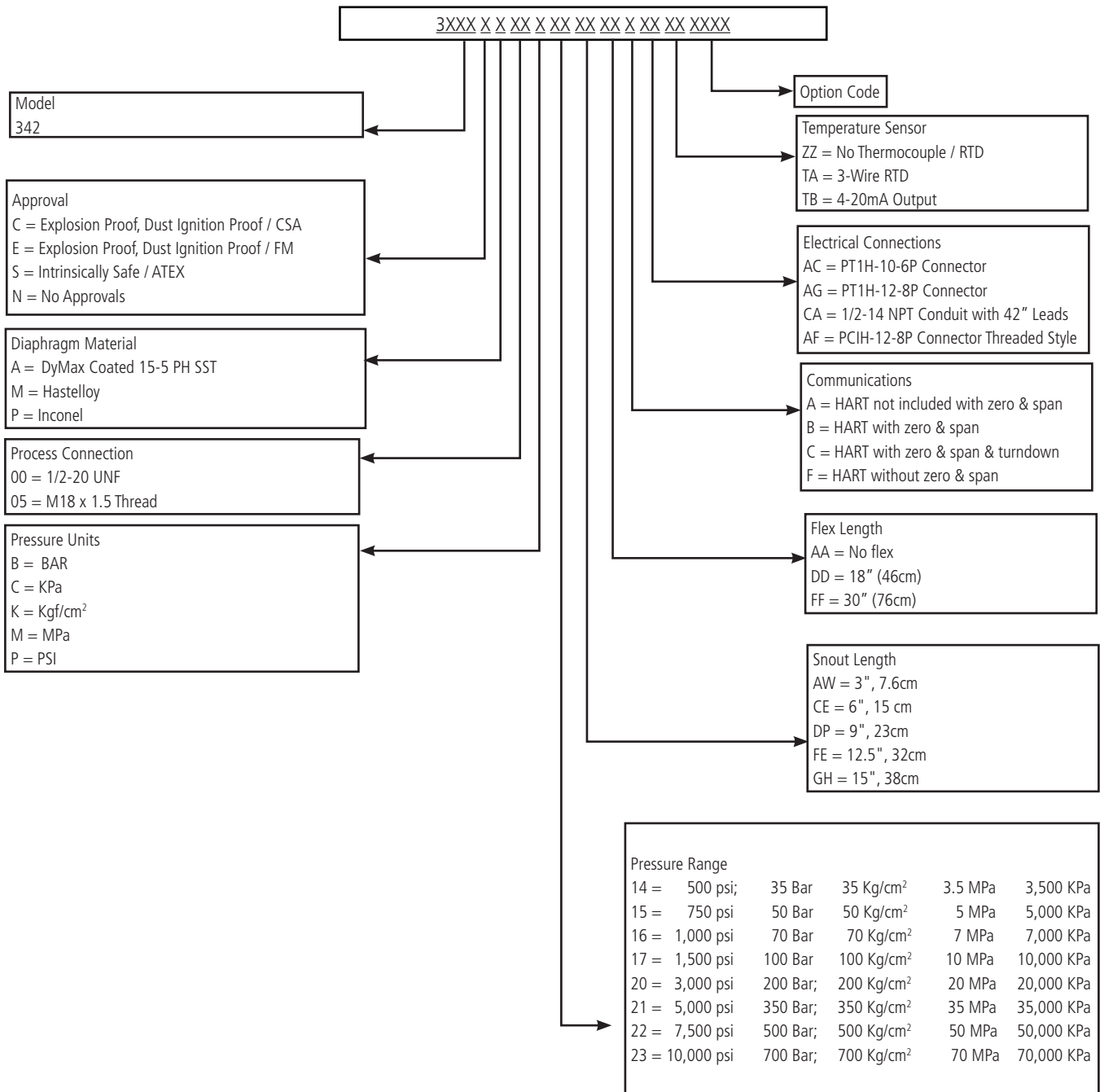

¹ Other configurations are available. Please consult factory.

Ordering Guide for Models SPX3343¹

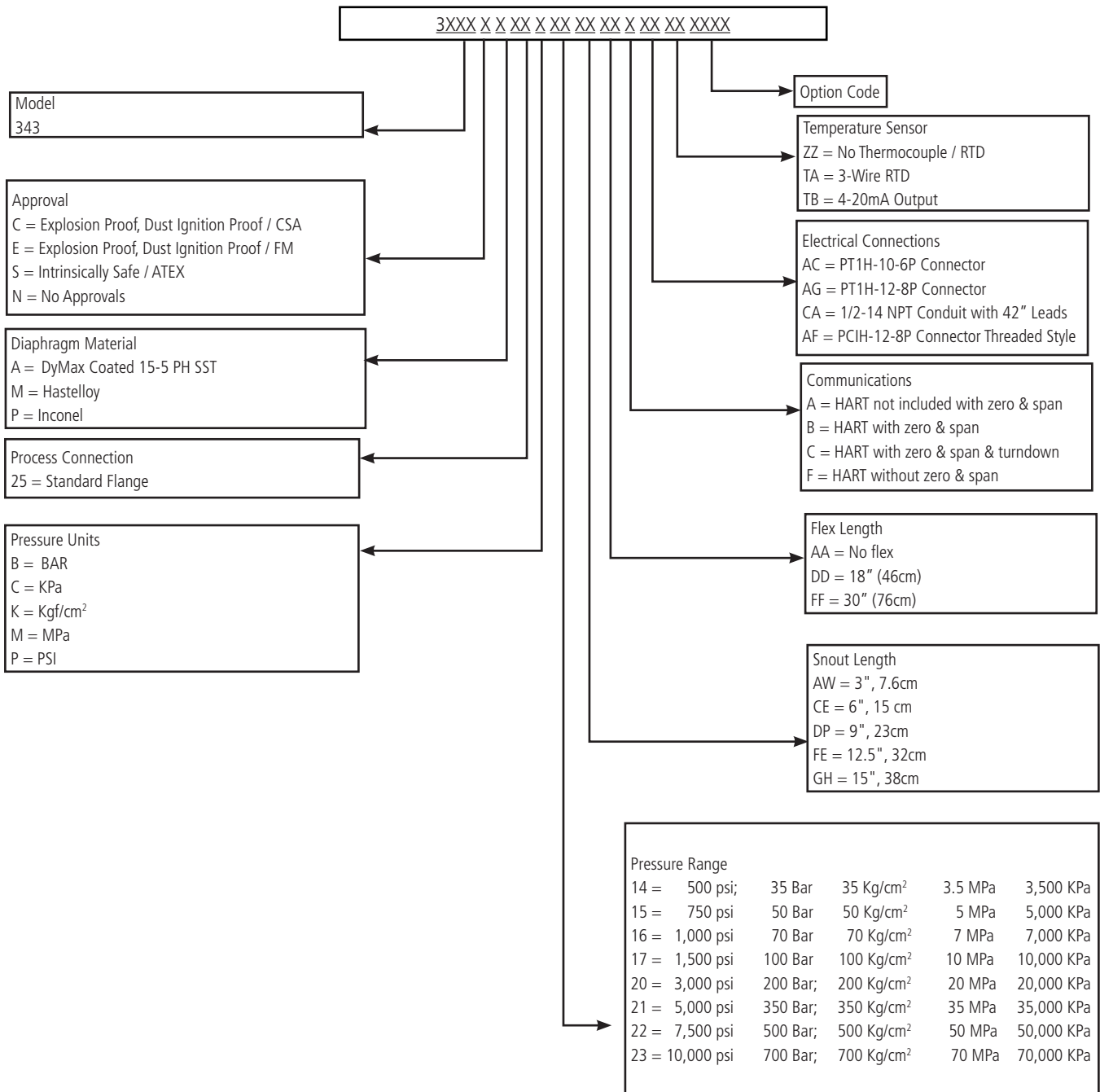

¹ Other configurations are available. Please consult factory.

Ordering Guide for Models SPX3290¹

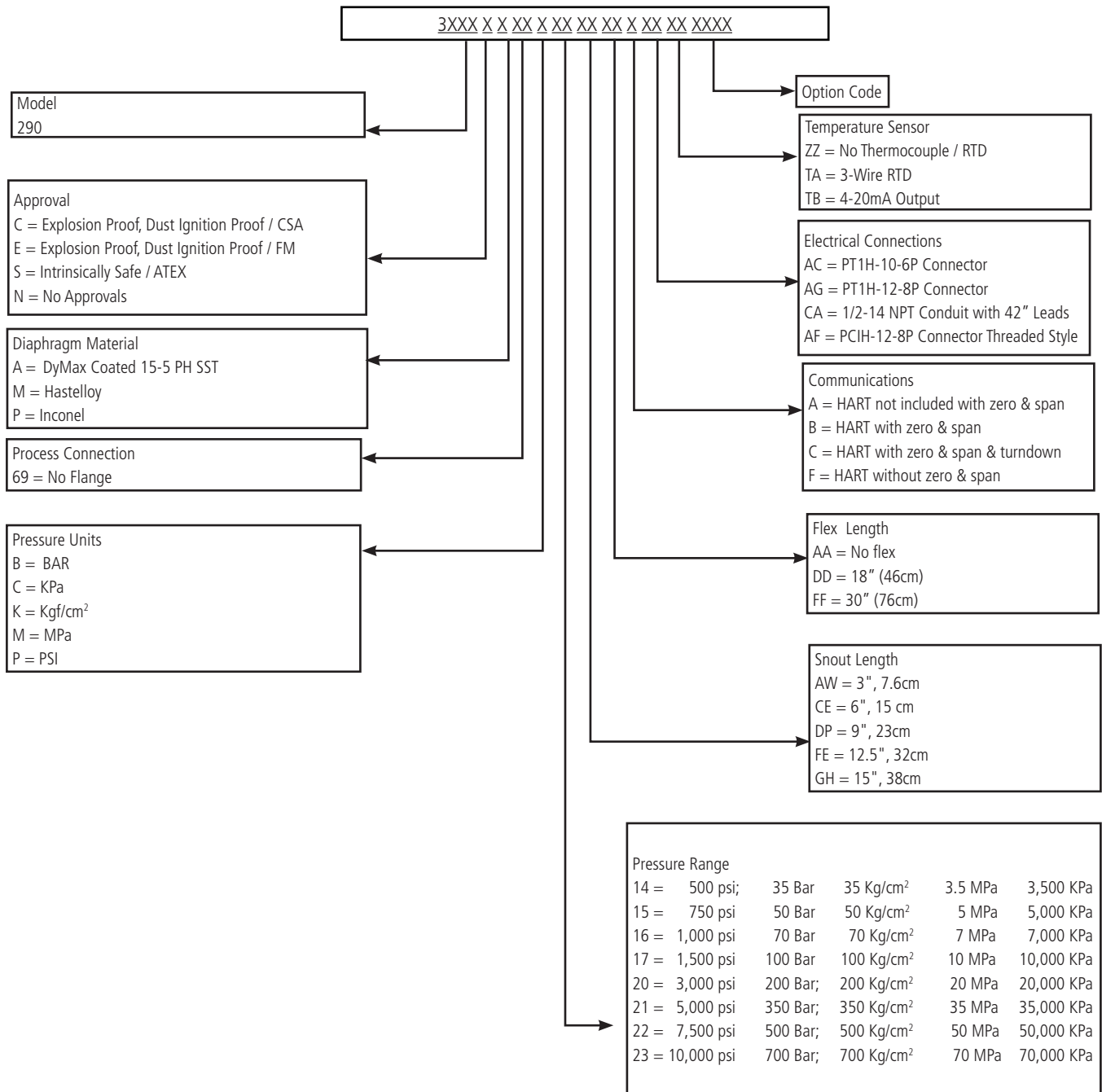

¹ Other configurations are available. Please consult factory.

Ordering Guide for Models SPX3291¹

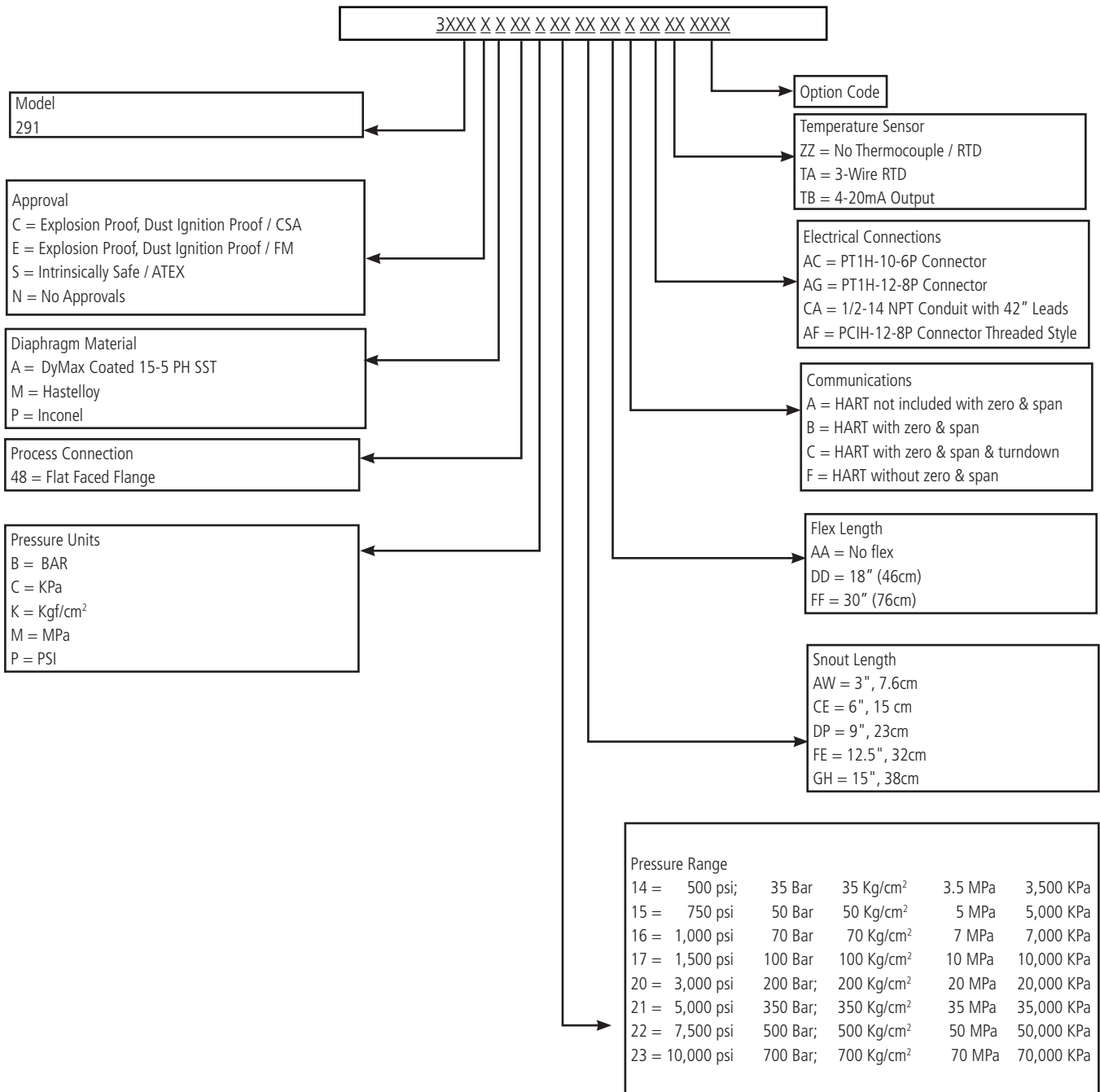

¹ Other configurations are available. Please consult factory.

Ordering Guide for Models SPX3390¹

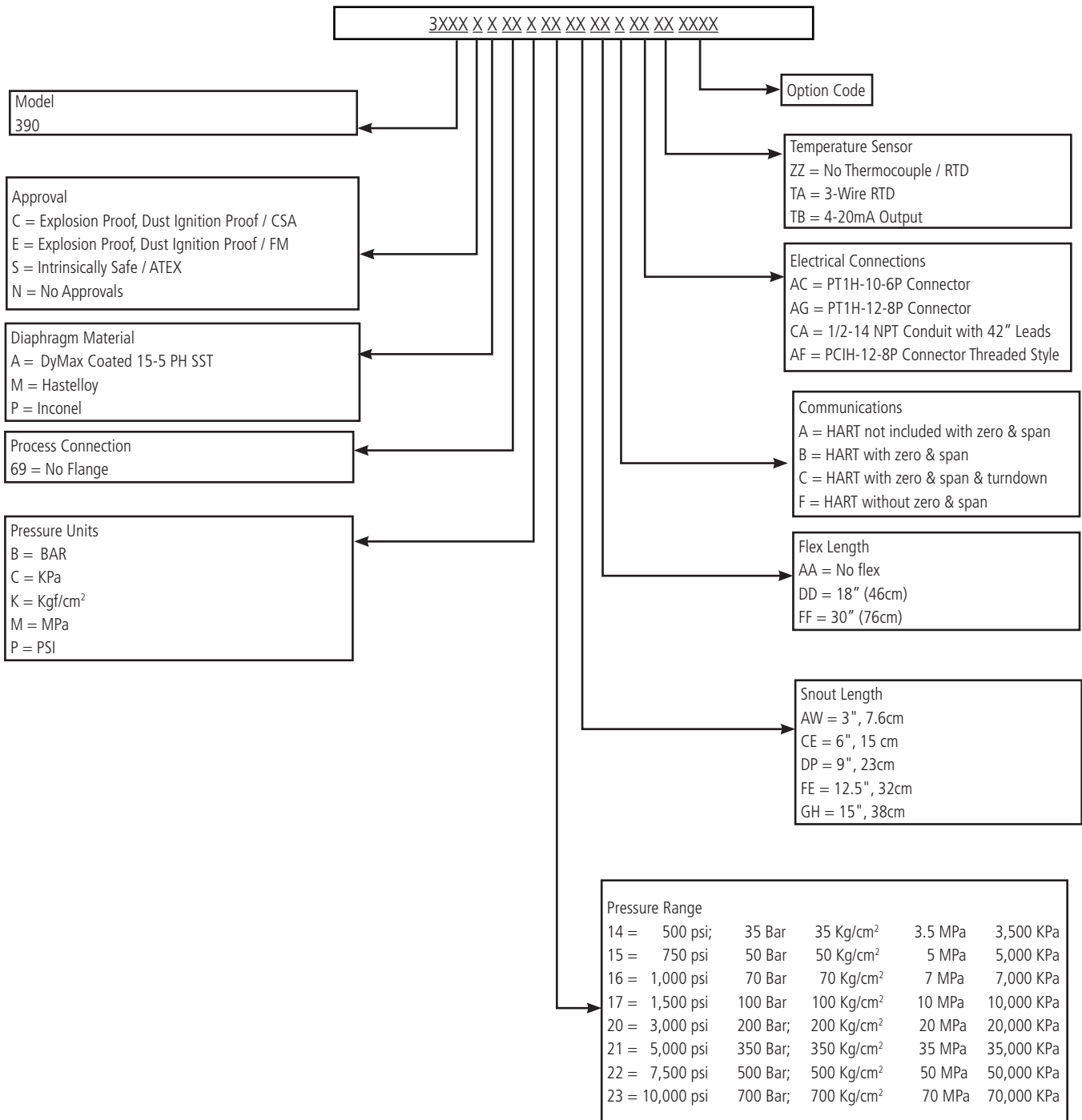

¹ Other configurations are available. Please consult factory.

Ordering Guide for Models SPX3391¹

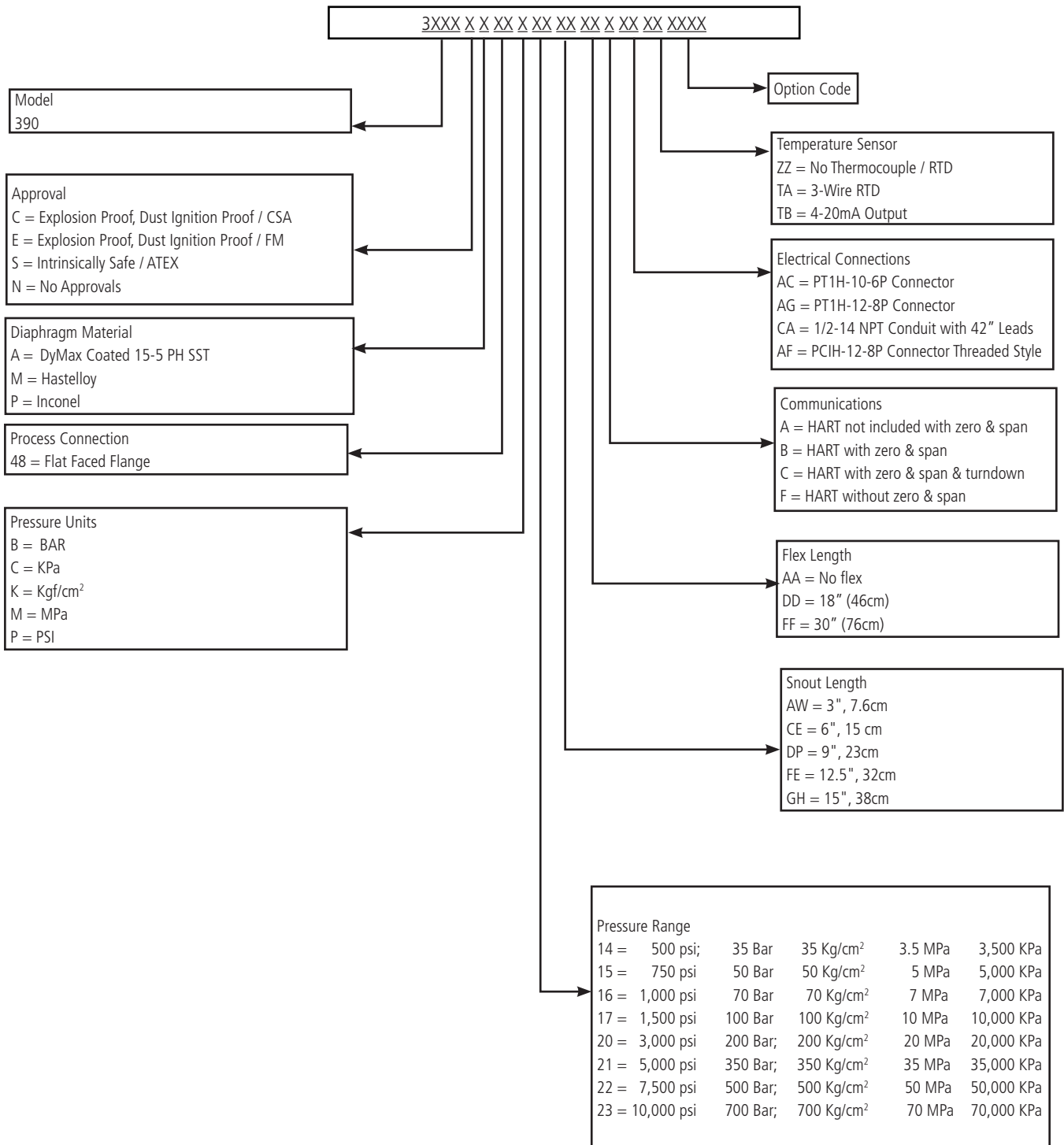

¹ Other configurations are available. Please consult factory.

REV	ECO	BY	APP	DATE
C	46553	TP	LEB	07/29/16

642001

DETAIL 'A'

ELECTRICAL HOUSING, CONNECTOR

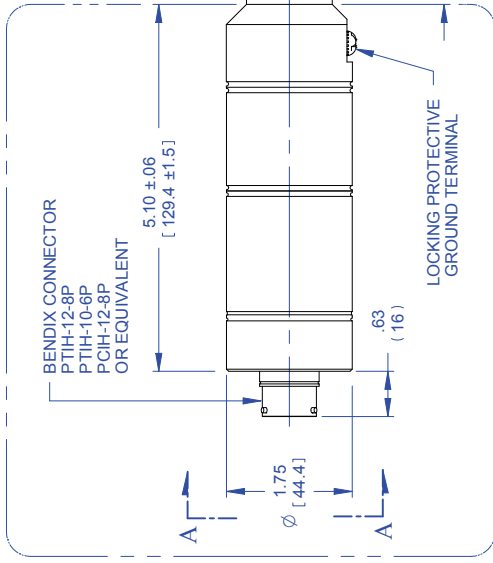

PER DETAIL 'A'

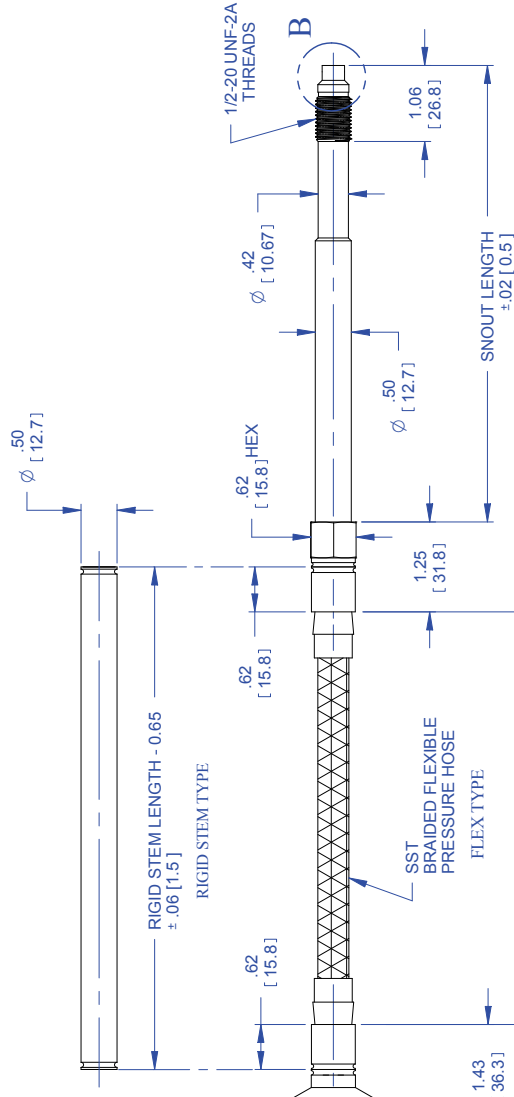
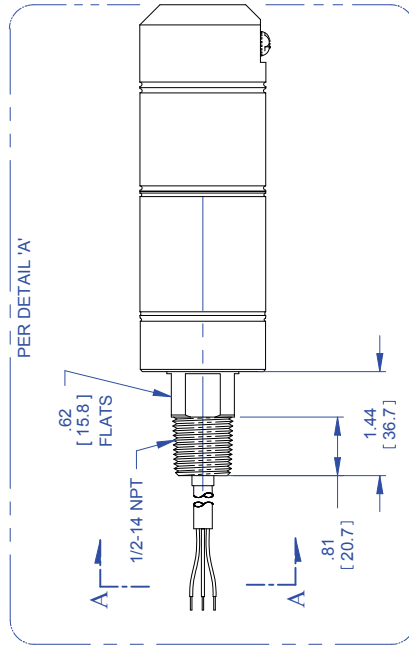

ZERO AND SPAN ADJUSTERS ARE PROTECTED BY SEAL SCREWS

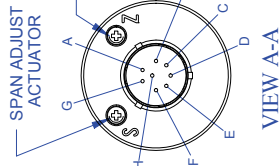
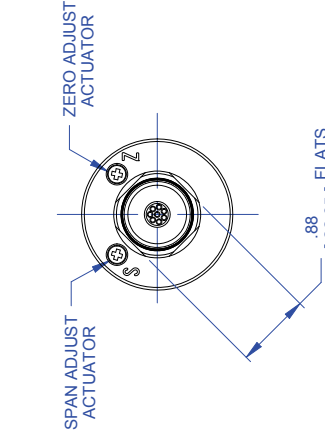

DETAIL 'B'

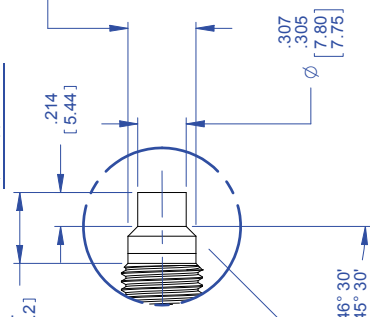

SIGNAL	TERMINAL DESCRIPTION	CONDUIT-LEAD WIRE COLOR	6-PIN	8-PIN
PRIMARY 4-20mA	PWR+/SIG+	RED	A	A
	PWR-/SIG-	BLACK	B	B
	CASE	GREEN	-	-
OPTIONS				
RCAL ONLY	RCAL+	ORANGE	F	E
	RCAL-	BLUE	E	D
RCAL WITH SECONDARY 4-20mA ONLY	RCAL+	ORANGE	-	D
	2ND PWR+/SIG+	BLUE	-	D
	2ND PWR-/SIG-	VIOLET	-	G
SECONDARY 4-20mA ONLY	2ND PWR+/SIG+	YELLOW	-	H
	2ND PWR-/SIG-	VIOLET	-	H
DUAL RTD ONLY	RTD (-)	WHITE	-	D
	RTD (+)	GREY	-	E
	RTD (+)	BROWN	-	F

NOTES:

- ALL DIMENSIONS ARE INCHES [MILLIMETERS]
- EXPOSED SURFACES ARE STAINLESS STEEL.

1. TO CHANGE UNLESS OTHERWISE SPECIFIED:
 2. UNLESS OTHERWISE SPECIFIED:
 3. PLACE DECIMAL 3.05
 4. ANGLES ±.05° MAX
 5. DIMENSIONS TO UNLESS OTHERWISE SPECIFIED
 6. ALL DIMENSIONS ARE IN INCHES

TITLE
 SPX-T
 MODELS 3342 3242
 OUTLINE DWG

EXCEPT AS MAY BE OTHERWISE PROVIDED BY CONTRACT, THESE DRAWINGS AND SPECIFICATIONS SHALL BE VOID IN THE EVENT OF A DISCREPANCY BETWEEN THE DRAWINGS AND THE PARTS LIST FOR THE MANUFACTURE OR SALE OF APPARATUS WITHOUT PERMISSION.

Dynisco
 FORGE INNOVATION TRANSFORMING IDEAS
 SIZE DIVC. NO. REV
 C 642001 C
 SCALE NONE SHEET 1 OF 1

MODEL NO. SPX-T
 DATE 01/30/07
 CHECKED MML DATE 05/27/08
 APPROVED MML DATE 05/27/08
 FINISH 63

DO NOT SCALE DRAWING
 MATERIAL

REV	ECO	BY	APP	DATE
C	46553	TP	LEB	07/29/16

643001

DETAIL 'A'

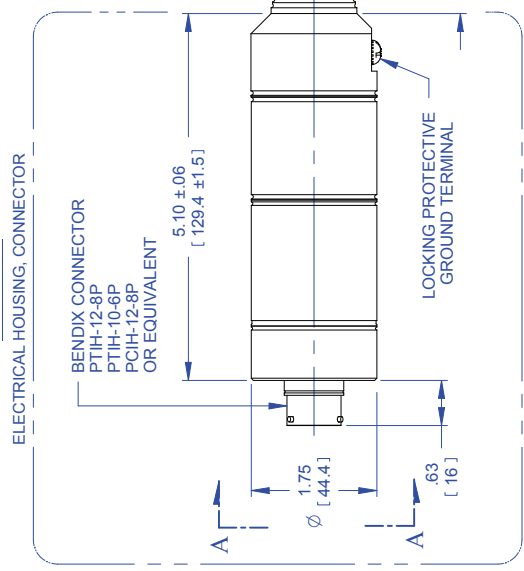

PER DETAIL 'A'

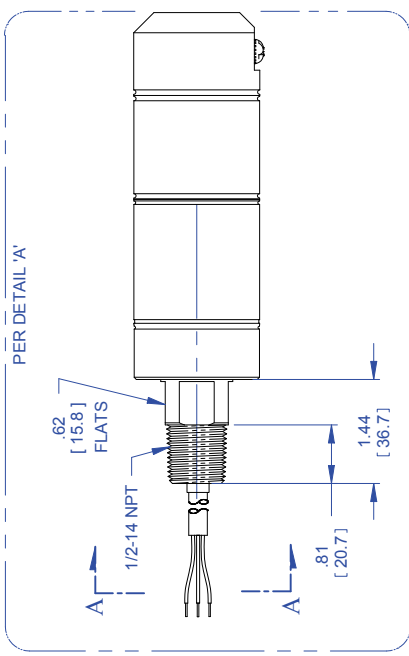

ZERO AND SPAN ADJUSTS ARE PROTECTED BY SEAL SCREWS

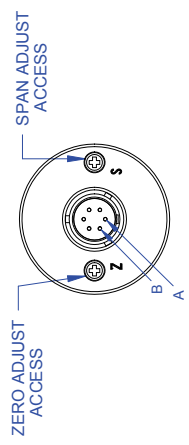

VIEW A-A

NOTES:
 1. ALL DIMENSIONS ARE INCHES [MILLIMETERS]
 2. EXPOSED SURFACES ARE STAINLESS STEEL.

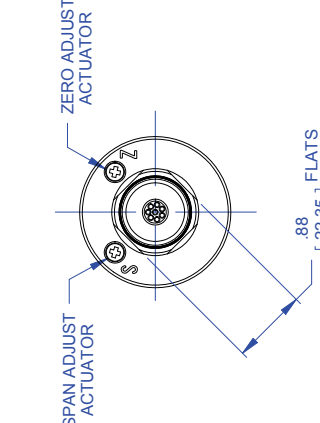
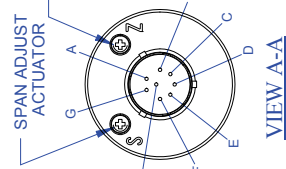
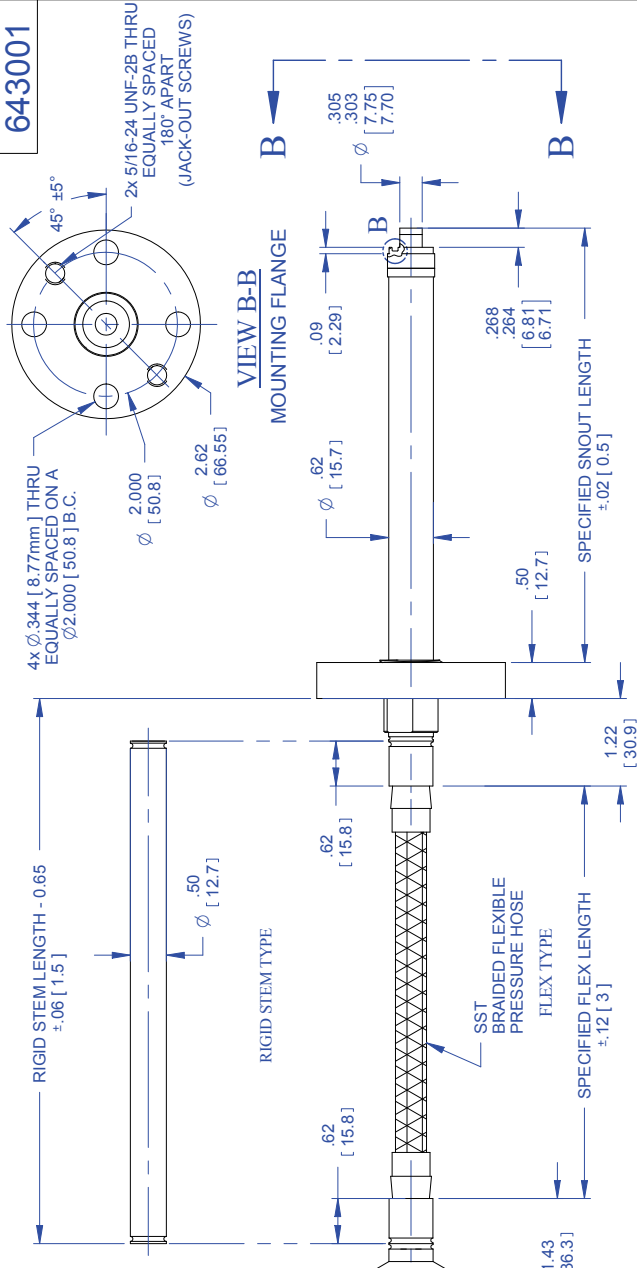

VIEW A-A

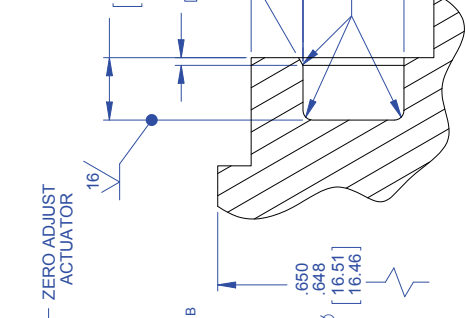

DETAIL 'B'
 O-RING GROOVE
 GROOVE FOR 1/2 NOM O.D. VENTED METAL O-RING, (SILVER PLATED)
 DYNISCO PIN 652116

SIGNAL	TERMINAL DESCRIPTION	WIRE COLOR	OPTIONS										
			RCAL+	RCAL-	RCAL+	RCAL-	2ND PWR+/SIG+	2ND PWR-/SIG-	2ND PWR+/SIG+	2ND PWR-/SIG-			
PRIMARY 4-20mA	PWR+/SIG+	RED	A	A	-	-	-	-	-	-	-	-	-
	PWR-/SIG-	BLACK	B	B	-	-	-	-	-	-	-	-	-
SECONDARY 4-20mA ONLY	RCAL+	ORANGE	F	F	-	-	-	-	-	-	-	-	-
	RCAL-	BLUE	E	E	-	-	-	-	-	-	-	-	-
	2ND PWR+/SIG+	VIOLET	-	-	-	-	-	-	-	-	-	-	-
	2ND PWR-/SIG-	YELLOW	-	-	-	-	-	-	-	-	-	-	-
SECONDARY 4-20mA ONLY	RTD (-)	WHITE	-	-	-	-	-	-	-	-	-	-	-
	RTD (+)	GREY	-	-	-	-	-	-	-	-	-	-	-
DUAL RTD ONLY	RTD (+)	BROWN	-	-	-	-	-	-	-	-	-	-	-
	RTD (-)	BROWN	-	-	-	-	-	-	-	-	-	-	-

1. TO BE FINISHED UNLESS OTHERWISE SPECIFIED:
 1. 1/2 FLAT BEZEL 1.05
 2. 1/2 FLAT BEZEL 1.05
 3. 1/2 FLAT BEZEL 1.05
 4. 1/2 FLAT BEZEL 1.05
 5. 1/2 FLAT BEZEL 1.05
 6. 1/2 FLAT BEZEL 1.05
 7. 1/2 FLAT BEZEL 1.05
 8. 1/2 FLAT BEZEL 1.05
 9. 1/2 FLAT BEZEL 1.05
 10. 1/2 FLAT BEZEL 1.05

TITLE
SPX-T
MODELS 3343 3243
OUTLINE DWG

EXCEPT AS MAY BE OTHERWISE PROVIDED BY CONTRACT, THESE DRAWINGS AND SPECIFICATIONS SHALL BE CONSIDERED AS A COMPLETE AND EXHAUSTIVE STATEMENT OF THE REQUIREMENTS FOR THE MANUFACTURE OR SALE OF APPARATUS WITHOUT PERMISSION.

Dynisco
 FORCE MAJEURE TRAINING, VA.
 DIV. NO. _____
 SIZE _____
 C 643001 C
 SCALE NONE SHEET 1 OF 1

MODEL NO. **SPX-T** DATE 01/30/07
 CHECKED _____ DATE 5/27/08
 APPROVED _____ DATE 5/27/08
 FINISH 63

DO NOT SCALE DRAWING
 MATERIAL _____

REV	ECO	BY	APP	DATE
A	46553	TP	LEB	07/29/16 R

000652

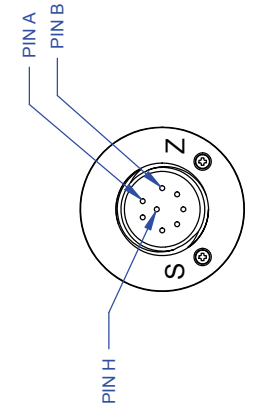

8 - PIN PC
O-RING WITH PUSH BUTTONS
PCIH-12-8P

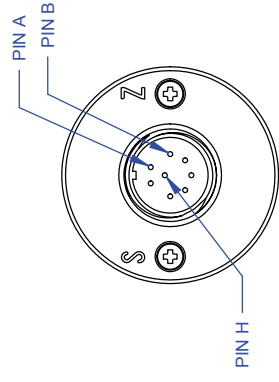

8 - PIN PC
WELDED WITH PUSH BUTTONS
PCIH-12-8P

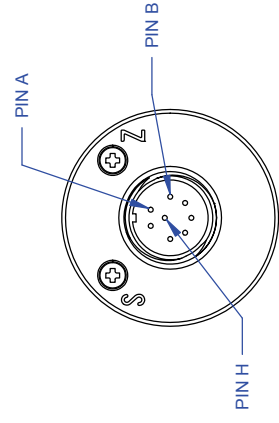

8 - PIN PC
WELDED WITH HALLS
PCIH-12-8P

GUARDIAN CONNECTOR WIRING	
PIN	FUNCTION
A	POWER +
B	SIGNAL -
C	POWER -
D	NO CONNECTION
E	Rcal -
F	Rcal +
G	RELAY CONTACT
H	RELAY CONTACT

NOTE:
1. THESE CONNECTOR OPTIONS ARE AVAILABLE ON MOST OF THE CONFIGURATIONS SHOWN ON THE PREVIOUS SHEETS.

TOLERANCES UNLESS OTHERWISE SPECIFIED:
 1. PLACE DECIMAL ± .005
 2. FRACTIONS ± 1/32
 3. DRILLS < 0.5 DIA. ± .002 > 0.5 DIA. ± .003
 4. ANGLES ± 0.5° MAX.
 5. EDGES R .006 OR CHAMFER MAX.
 6. PART TO BE FREE OF BURRS
 7. PART TO BE FREE OF BURRS
 8. ALL DIMENSIONS ARE IN INCHES.

TITLE		DATE	
GUARDIAN SERIES CONNECTORS		TP	7/27/16
DRAWN	CHECKED	DATE	DATE
LEB	LEB	7/27/16	7/27/16
APPROVED	APPROVED	FINISH	63 ✓
FINISH	FINISH	MATERIAL	X

SIZE		REV	
B		A	
DWG. NO.		REV	
000652		A	
SCALE NONE SHEET 1 OF 1			

EXCEPT AS MAY BE OTHERWISE PROVIDED BY CONTRACT, THESE DRAWINGS AND SPECIFICATIONS ARE THE PROPERTY OF DYNISCO. ANY REPRODUCTION, REPRODUCTION OR COPIED, OR USED AS THE BASIS FOR THE MANUFACTURE OR SALE OF APPARATUS WITHOUT PERMISSION.



FORGE PARKWAY, FRANKLIN, MA 01917

©2016. Dynisco reserves the right to make changes without notice.
Refer to www.dynisco.com for access to Operator Manual and other support documentation.
PN: DSSPX3SERIES
REV: 072016
ECO: 46503



Product Safety
Functional
Safety
www.tuv.com
ID: 0560000000



www.dynisco.com

Dynisco

38 Forge Parkway
Franklin, MA 02038
USA

Hotline 1-800-Dynisco
www.dynisco.com
Phone +1 508 541 9400
Fax +1 508 541 6206
Email infoinst@dynisco.com

Dynisco Europe, GmbH

Pfaffemstr. 21 Phone +49 7131 297 0
74078 Hellbronn Fax +49 7131 297 166
Germany Email dyniscoeurope@dynisco.com

Dynisco Shanghai

Building 7A, No. 568 Phone +86 21 34074072-819
Longpan Rd Malu Toll Free +86 400 728 9117
Jiading, 201801 China Fax +86 21 34074025